



User's Manual

XK3101(HL-2065) Indicator

Contents

1. Main Data	1
2. Main Functions	1
3. Construction	2
4. Installation Connection	4
5. Operation Keys Instruction	4
6. Use Instruction	5
6.1 Turn-on Operation	5
6.2 Turn-off Operation	5
6.3 Zeroing	5
6.4 Deducting Tare	5
6.5 Conversion between “kg” and “lb”	6
6.6 Basic Counting Mode	6
6.7 RS-232 Output	6
6.8 Bill-printing output	7
6.9 Digit Input	8
7. Use Guide	8
8. Calibration	9
9. Simple Rectifying	12
10. Information Prompt	13

1. Main Data

- 1.1 Zero-load signal input range : 0 ~10mV
- 1.2 Zero temperature-drift : $\leq 0.15\mu\text{v}/^\circ\text{C}$
- 1.3 Sensitivity temperature-drift : $\leq 12 \text{ ppm}/^\circ\text{C}$
- 1.4 A/D conversion resolution ration : 300000
- 1.5 Display resolution ration : 30000
- 1.6 A/D conversion rate: 100T/S
- 1.7 Display shift rate : 5T/S
- 1.8 Non-linearity : $\leq 0.01\%F\cdot S$
- 1.9 Load cell exciting power : DC5V, driving 4 load cell of 350Ω
- 1.10 Using temperature : $0^\circ\text{C} \sim 40^\circ\text{C}$
- 1.11 Relative humidity : $\leq 90\%RH$ (no condensation)
- 1.12 Storage environment temperature : $-25^\circ\text{C} \sim 55^\circ\text{C}$
- 1.13 Min. display value : optional
- 1.14 Display style : 6-digit 0.56-inch 7-segment LED
- 1.15 16 grades of Max. weighing to be selected : 3kg~5000kg
- 1.16 Baud rate for data output to be selected : 1200
- 1.17 Power supply : AC110V/220V/230V/240V, 60/50Hz

Note: For the actual value, see the nameplate on the indicator.

- 1.18 Installation style : Tower mode or table mode or wall mode
- 1.19 Dimension (L×H×W) : XK3101 (HL-2065B) 248×125×162mm
XK3101 (HL-2065C) 162×125×167mm
- 1.20 Dead weight (kg) : XK3101 (HL-2065B) $\leq 2.6\text{kg}$
XK3101 (HL-2065C) $\leq 1.5\text{kg}$

2. Main Functions

- 2.1 Full keyboard calibrating
- 2.2 Zero position auto-tracking
- 2.3 Full range deducting-tare
- 2.4 Over load indicating
- 2.5 Simple counting
- 2.6 Two kinds of calibration modes : Fixed point and arbitrary point calibrating
- 2.7 Extension display (i.e. internal code display function)
- 2.8 RS-232C output (optional)
- 2.9 Bill-printing output (optional)
- 2.10 Conversion between weighing and counting mode
- 2.11 Weight unit selecting and converting (kg or lb)

Note: There are Item 2.5, 2.9, 2.10 functions only when the software version is higher than Sr 0.05.

3. Construction

3.1 Structure drawing

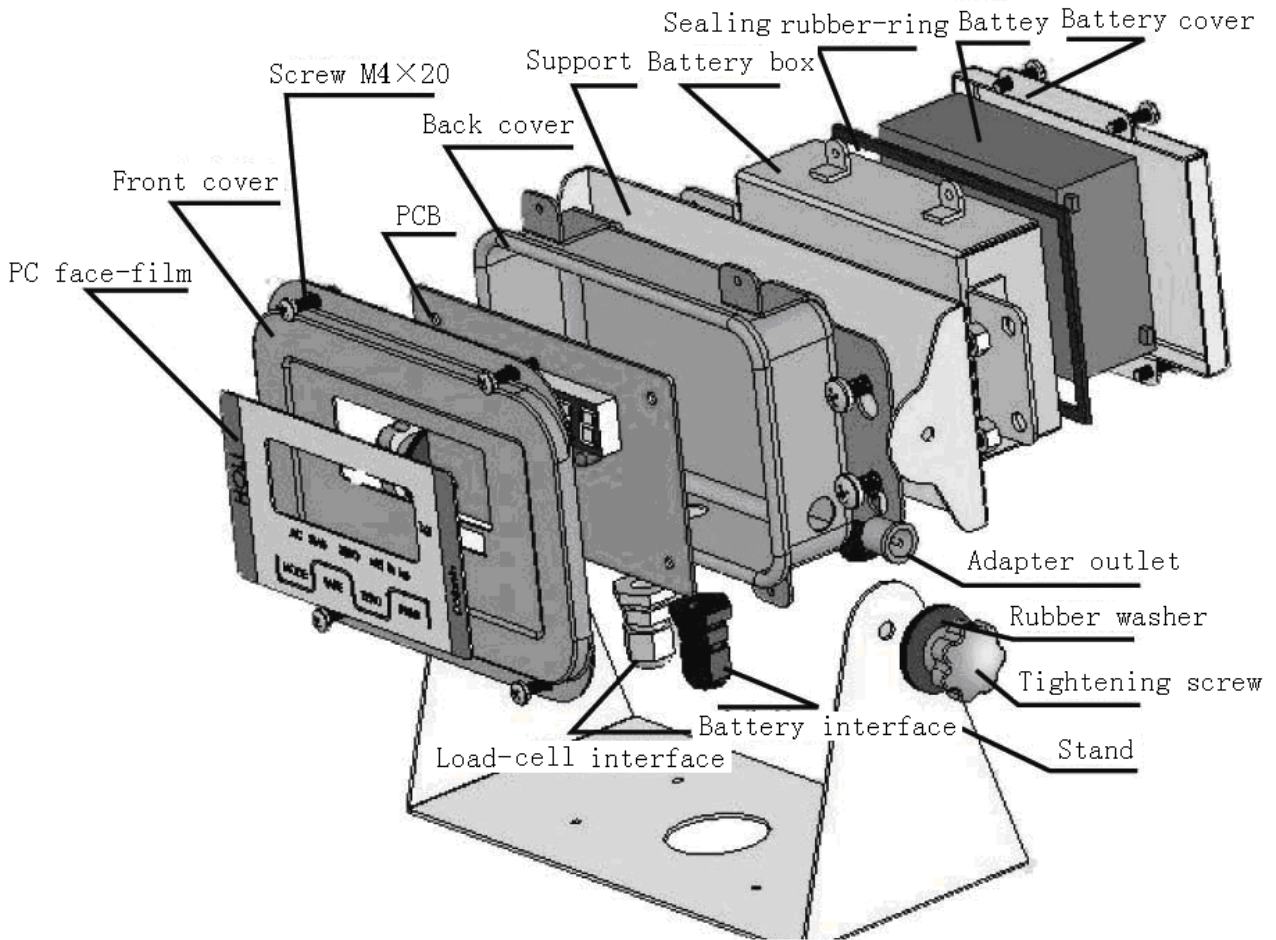

Figure 1: XK3101 (HL-2065B)

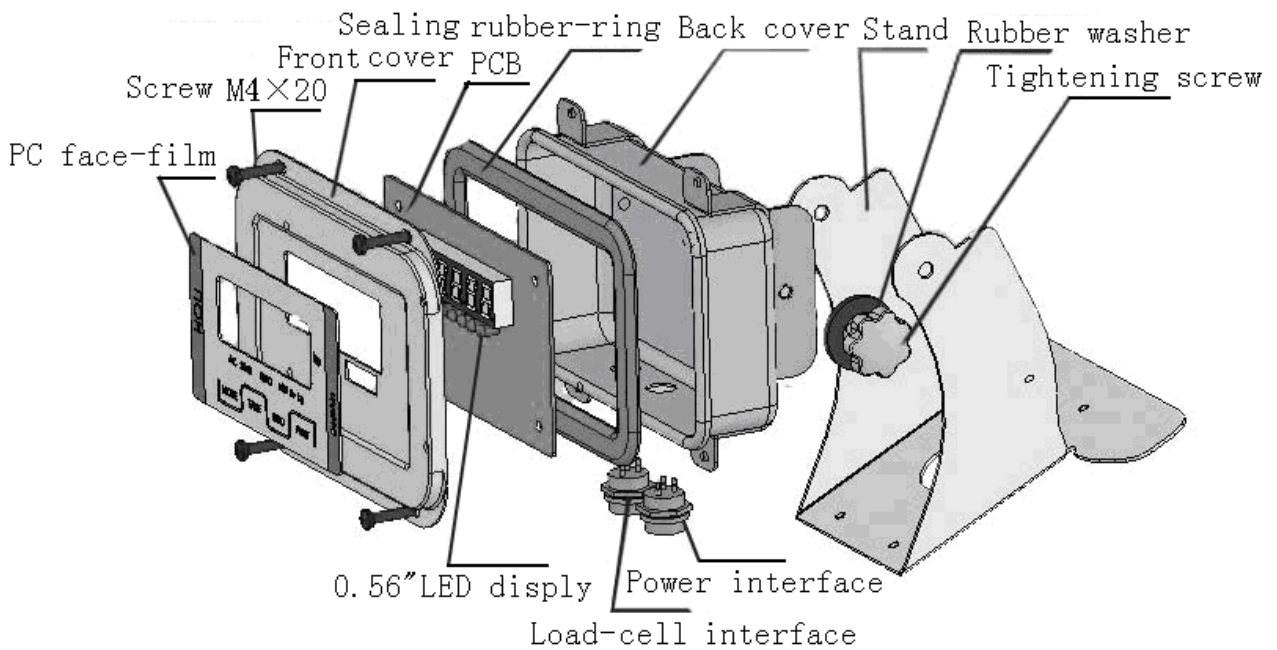

Figure 2: XK3101 (HL-2065C)

3.2 Panel

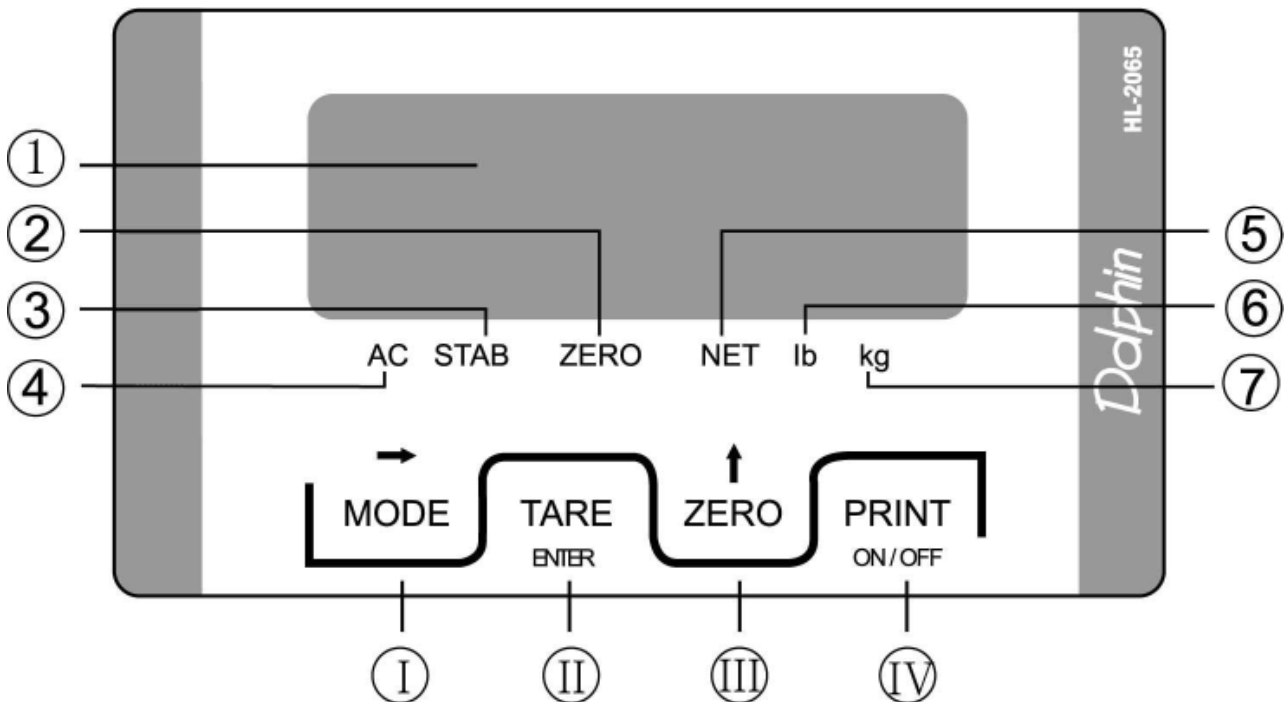

Figure 3: Panel

- ① 6-digit LED
- ② “ZERO” indicating light
- ③ “STAB” indicating light
- ④ “AC” indicating light
- ⑤ “NET” indicating light
- ⑥ “lb” indicating light
- ⑦ “kg” indicating light
- Ⅰ [MODE]/[→] key
- Ⅱ [TARE]/[ENTER] key
- Ⅲ [ZERO]/[↑] key
- Ⅳ [PRINT]/[ON]/[OFF] key

3.3 Cursors and their meanings

There are 6 LED indicating-cursors on this indicator, for the names and meanings, see the following table:

Cursor symbol	Meaning
“AC”	Appears when AC power is used
“STAB”	Appears when the weighing is stable
“ZERO”	Appears when the weighing is within 1/4d
“NET”	Appears when the display value is net
“lb”	Appears when the weight unit selected is “pound”

“kg”

Appears when the weight unit selected is “kilogram”

4. Installation connection

4.1 If power adapter input, for its pole, see Figure 4a.



Figure 4a: Power adapter input

4.2 Load cell input

4.2.1 If the 5-core aerial outlet is used for the load cell connecting, see Figure 4b.

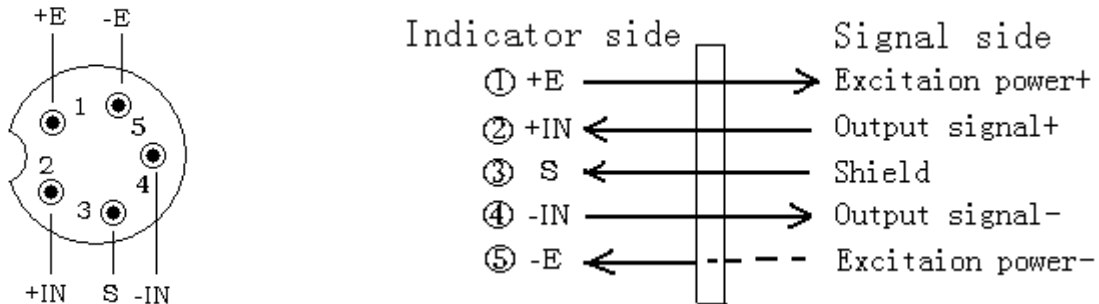

Figure 4b: Wire-connecting between load cell and 5-core aerial pin-outlet

4.2.2 If the 9-core D-shape plug is used for the load cell connecting, see Figure 4c.

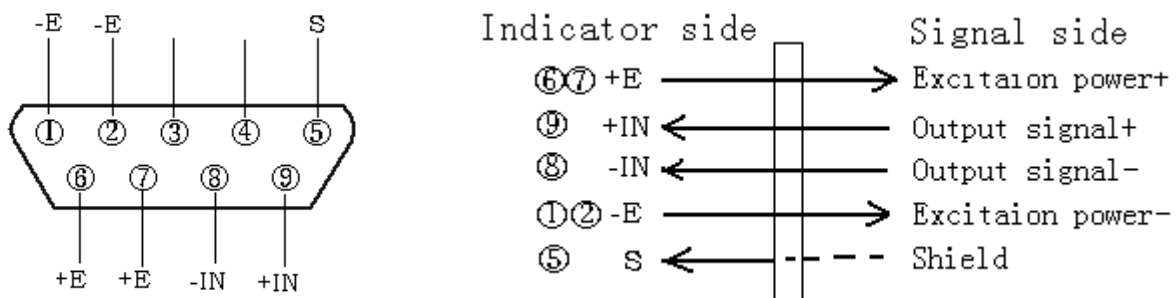

Figure 4c: Wire-connecting between load cell and 9-core D-shape plug

Note: Make sure that the connection between the load cell and the indicator is reliable and the shield wire for the load cell is reliably grounded. Don't insert or pull the plug of the connection cable under power-on state for the indicator, lest the static electricity damages the indicator or the load cell. Never process the welding or the other heavy-current operation on the indicator directly.

5. Operation Keys Instruction

[ZERO]/[↑] key

- Under weighing state, you can use this key to make the display return to zero.
- Used for increasing the value of the selected figure.
- Under weighing state, keep pressing this key for 3 seconds, the indicator will automatically convert the weight unit between “kg” and “lb”.

[TARE]/[ENTER] key

- a. Under weighing state, you can use this key to deduct tare.
- b. Under calibrating state, you can use this key to definite the present state (result), at the same time the indicator will prompt to enter the next step.

[ON]/[OFF] /[PRINT] key

- a. Used for power-on and power-off.
- b. Under weighing state, press this key, the serial interface will export the print signal.

[MODE]/[→] key

- a. Used for converting the mode between weighing and counting.
- b. Under calibrating state, you can use this key to choose the setup method or the given parameter table, also use it to shift place while inputting the weight value on arbitrary point.
- c. Under normal weighing state, keep pressing this key for 3 seconds, the indicator will enter the simple calibration state.

6. Use Instruction

6.1 Turn-on Operation

Caution: Make sure that the power voltage is within the required range before power-on.

Under power-on state, press [ON], firstly the indicator displays its model and then its edition number; secondly it automatically checks the strokes from “9” to “0” and then enters weighing state.

6.2 Turn-off Operation

Under normal weighing state, keep pressing [OFF] for 3 seconds, at this time the indicator displays “OFF” and then it is turn off automatically .

6.3 Zeroing

When the weight value displayed by the indicator is less than $2\%F \cdot S$, press [ZERO] to make the display return “0” and at the same time the “ZERO” cursor appears. While carrying through repeat zero, you can make the display of not more than $5\%F \cdot S$ return zero. When the “NET” indicating cursor is on, can't carry through zeroing operation.

6.4 Deducting Tare

6.4.1 When the goods is placed on the scale platform and if the weight is regarded as tare to deduct, press [TARE], the indicator displays “0” and at the same time “NET” cursor appears. If you need to deduct tare continually, the adding weight should not be more than the Max. weighing.

6.4.2 For the process that the negative tare appears and is cleared, see the following table.

Steps	Display	Meaning
Place goods on the scale platform	0.50	Which means the goods weight is 0.5kg (can be regarded as tare) .
Press [TARE]	0.00	The tare has been deducted, and at this time the “NET” indicating cursor appears.
Remove the goods	-0.50	The indicator displays the tare (negative value)

Press [TARE] again	0.00	The negative tare is cleared, and at the same time the “NET” indicating cursor is off.
--------------------	------	--

6.5 Conversion between “kg” and “lb”

Under weighing state, keep pressing [ZERO] for 3 seconds, the indicator automatically converts the weight unit between “kg” and “lb”, and at the same time the relevant “kg” or “lb” cursor is on.

6.6 Basic Counting Mode

Under weighing state, press [MODE], the indicator enters the sampling state.

6.6.1 Sampling

After entering basic counting mode, the indicator displays “PC 2”. When you press [↑], you can make the sample number change in 2→5→10→20→50→100→200→2 order in circle, once you decide on the sample number (of course, the larger the number, the better the result), now you can place the sample article whose number is equal to the displayed number on the scale platform. After awaiting the stabilization cursor “STAB” appear, press [TARE] to confirm.

Note: You should place the samples with verified amount on the scale platform almost at the same time. And the weight of single sample should approach the display division value as far as possible.

6.6.2 Counting

After finishing the sampling-operation, you can load the even-weight article like sample on the scale platform, at this time the indicator displays the article amount on the scale platform.

6.6.3 Entering weighing-state

Under basic counting state, press [MODE], the indicator withdraws from counting state and enters weighing mode at the same time.

6.7 RS-232 Output

6.7.1 The 3-core aerial outlet is used for RS-232 hardware interface, and the outlet is mounted on the back housing of the indicator, see the following drawing:

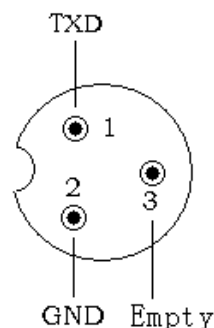

Figure 5: 3-core metal outlet

6.7.2 The indicator serial interface transmits data in MCS-51 mode 1, and the data are sent out in ASCII method. Every group has 17 frames including 1 frame of start character (02), 3 frames of

state mark, 6 frames of displaying data, 6 frames of tare data and 1 frame of enter. For the details, see the following drawing:

STX State A State B State C Display Value Tare Value Enter
 Serial output pattern

STX : start character, 02H

State A : control character for decimal point (D7 refers to verification bit)

D7	D6	D5	D4	D3	D2	D1	D0	Decimal point place
Verification bit	0	1	0	1	0	1	0	Without decimal point
	0	1	0	1	0	1	1	1-digit decimal 0.0
	0	1	0	1	1	0	0	2-digit decimal 0.00
	0	1	0	1	1	0	1	3-digit decimal 0.000
	0	1	0	1	1	1	0	4-digit decimal 0.0000

State B: comprehensive control character

D7	Verification bit	
D6	0	
D5	1	
D4	1	
D3	Dynamic mark bit	D3=0, stability; D3=1, non-stability (dynamic)
D2	Overload mark bit	D2=0, normality; D2=1, overload
D1	Positive and negative mark bit	D1=0, positive number; D1=1, negative number
D0	Gross weight and net weight mark bit	D0=0, gross weight; D0=1, net weight

State C: output empty case character

6.7.3 Every frame consists of 10 digits. The first is start bit, "0". The ninth is stop bit, "1". One of the other eight is correction bit and the other seven are all data bits (from low to high), the pattern is as follows:

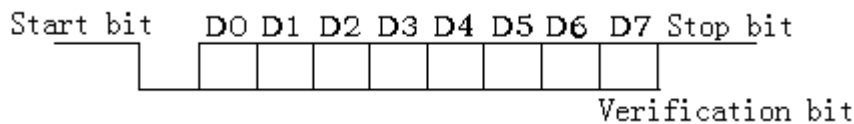

Figure 6: Frame pattern

6.8 Bill-printing output

6.8.1 Indicator data selecting

This indicator can be connected with TPμP-16S mini-printer. For communication with the printer, you should turn the indicator setup data into F6=1 and make sure that the F7 value is equal to the Baud rate of the printer. At this time, press [PRINT] on the indicator, the printer prints the following bill mode (optional).

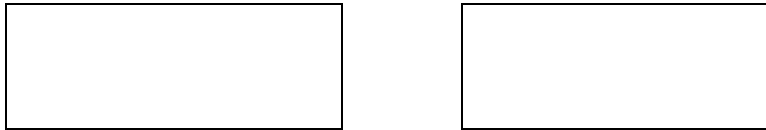

Figure 7: Bill mode

6.8.2 Connection between the indicator and the printer

Connect an end of printer cable to the D-shape 25-core joint (pin) for the printer and the other end to 5-core metal outlet for the indicator. See the following drawing.

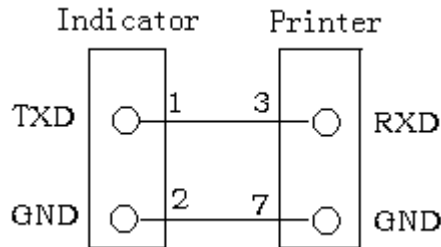

Figure 8: Connection between the indicator and the printer

6.8.3 Printing pattern Instruction

- A. When the net weight is negative, it doesn't print.
- B. The order number is "0~99". It automatically returns to zero when the number is over 99.

6.9 Digit Input

While processing the calibration operation, you need to input the digit. The digit input is all fulfilled via [→] and [↑] key in cooperating. [→] refers to place-shifting key, it is used for selecting digit place and the digit of the selected place will flash, at this time if you press [↑], the flashing digit of the selected place will be changed in "1→2→3→.....→9→0→1" sequence.

For instance: How to input digit "001500"!

If the display content on the indicator is 030000 when digit input, the digit input steps are as follows:

- Step 1:** Press [→] once to make the indicator clear, at this time the digit at the last right flashes and the indicator displays 00000"0".
- Step 2:** Press [→] once, the second digit at the last right flashes and 0000"0"0 is displayed.
- Step 3:** Press [→] once, the third digit at the last right flashes and 000"0"00 is displayed.
- Step 4:** Press [↑] five times, the indicator displays 000"5"00 and "5" flashes.
- Step 5:** Press [→] once, the fourth digit at the last right flashes and 00"0"500 is displayed.
- Step 6:** Press [↑] once, the indicator displays 00"1"500 and "1" flashes.
- Step 7:** Press [TARE] to confirm. Thus the input operation for a group of digit is completed.

7. Use Guide

- 7.1 Be sure that the ground terminal of AC power is properly grounded.
- 7.2 Weighing (tare included) can't exceed Max. Capacity plus 9e ("e" refers to graduation). If exceed, the indicator displays "OVER".
- 7.3 Don't disassemble it without authorization.

- 7.4 After turn-on, if the indicator doesn't display or its display don't change, at this time you can try to turn off its power and turn on its power again.
- 7.5 When you set "F1" data, you may have not enough patients or make a mistake. If you don't intend to be a more professional personnel, you only need to make F7= 1, thus you must not consider selecting the other data of F1~F6 because at this time the indicator (scale) can automatically select the setup value of the products leaving the company.
- 7.6 Turn off its power at once if the indicator is out of order in use. Non-specialized manufacturer or non-professional staff can't fix it without authorization. Users can contact our selling agent in your area.
- Caution:** Never change its data presumptuously once when the indicator can normally be operated, unless the act is permitted by the laws.
- 7.7 If you need to re-calibrate the indicator, do it after the indicator is turned on for 30 minutes in order to ensure its circuit in stable working state.

8. Calibration

8.1 Calibrating and data setting

There are 2 methods for you to enter setting / calibrating mode.

a. Don't need to open the indicator front-cover.

After power-on, keep pressing [MODE] and [ZERO] while the indicator is self-checking "0 ~ 9", loose the 2 keys at the same time if the indicator displays "Und0". At this time the indicator displays "CAL X" ("X" refers to 0 or 1 or 2) after "SET UP" is displayed for about 2 seconds. Now the indicator enters setting / calibrating state.

b. Need to open the indicator front-cover.

For entering setup/calibration, open its front cover, find out the short circuiter W1 and join 2 and 3 pin short. At this time the indicator automatically enter setup/calibration mode and displays "CAL 0" after "SET UP" is displayed for about 2 seconds. Now the indicator enters setting / calibrating state.

Note: Under setup/calibration mode, you can set the data by using the following keys.

[↑] : used for increasing the value of the selected place.

[ENTER] : used for confirming the selected value and entering the next-grade data setup.

[→] : used for selecting the setup mode or selecting the given data-table or shifting place while inputting the weight value on arbitrary point.

8.2 Entering calibration or ambient data group

"CAL X" refers to fixed point calibration / arbitrary point calibration /no calibration, you can use [→] to select the calibration mode, the method are as follows:

"X=0" refers to no calibration, press [ENTER] to enter the ambient data group

"X=1" refers to fixed point calibration, press [ENTER] to enter the indicator calibration (range fixing).

"X=2" refers to arbitrary point calibration, press [ENTER] to enter the indicator calibration (range arbitrary point).

Note: the weight value of the calibration weights is $5\%W_{max} < W_{add} < W_{max}$, W_{max} refers to full range and W_{add} refers to the loading-weights value.

8.3 Calibration process

Step 1: full range and division selecting

Use [→] to select the full range value to be calibrated, then press [ENTER] to confirm. At this time the indicator enter division selecting, also press [ENTER] to confirm after selecting division.

[CAP 3] refers to full range selecting:

The indicator displays full range data to be selected after it displays “CAP” data for about 2 seconds. At this time you can press [→] to select the full range value, and then press [ENTER] to confirm. After the operation is finished, the indicator enters division selecting.

[DIV 0.01] refers to division selecting

The indicator displays division data to be selected after it displays “DIV” data for about 2 seconds. At this time you can press [→] to select the division, and then press [ENTER] to confirm. After the operation is finished, the indicator enters zero-load adjustment state.

For the range and division, see the following table:

Max. range	Division	Fixed calibration value
3 kg	0.0001kg; 0.0002 kg ; 0.0005 kg ; 0.001 kg ;	2 kg
6 kg	0.0002kg; 0.0005 kg ; 0.001 kg ; 0.002 kg ;	5 kg
15 kg	0.001 kg ; 0.002 kg ; 0.005 kg ; 0.01kg	10 kg
30 kg	0.001kg 0.002 kg ; 0.005 kg ; 0.01 kg ;	20 kg
60 kg	0.002kg; 0.005 kg ; 0.01 kg ; 0.02 kg ;	30 kg
75 kg	0.005 kg ; 0.01 kg ; 0.02 kg ; 0.05 kg	50 kg
100 kg	0.005 kg ; 0.01 kg ; 0.02 kg ; 0.05 kg	50 kg
150 kg	0.01 kg ; 0.02 kg ; 0.05 kg ; 0.1kg	100 kg
200 kg	0.01kg; 0.02 kg ; 0.05 kg ; 0.1 kg ;	100 kg
250 kg	0.01kg; 0.02 kg ; 0.05 kg ; 0.1 kg ;	100 kg
300 kg	0.01kg; 0.02 kg ; 0.05 kg ; 0.1 kg ;	200 kg
600 kg	0.02kg; 0.05 kg ; 0.1 kg ; 0.2 kg ;	300 kg
1000 kg	0.1 kg ; 0.2 kg ; 0.5 kg ; 1 kg	500 kg
2000 kg	0.1kg; 0.2 kg ; 0.5 kg ; 1 kg ;	1000 kg
3000 kg	0.1kg; 0.2 kg ; 0.5 kg ; 1 kg ;	1000 kg
5000 kg	0.2kg 0.5 kg ; 1 kg ; 2 kg ;	2000 kg

Step 2: zero-load adjusting

Remove the goods on the scale platform after the indicator display “E SCL”, await 10 seconds and then press [ENTER] to confirm. At this time the indicator automatically reads the zero datum of the scale and enters range calibrating.

Step 3: range calibrating

If you select "CAL 1", the indicator enters the following "a". The indicator enters "b" when you select "CAL 2"

a. Fixed point calibration

Await several seconds, the indicator displays "Ad LD". Load the weights on the scale platform after the indicator display "Ad LD" for 2 seconds. Await 10 seconds (make sure that the indicator is fully stable), then press [ENTER] to confirm, at this time the indicator displays "PASS"(the indicator is reading the range datum of the scale). After several seconds, the indicator automatically turns to the ambient data group, thus the range calibrating is finished.

b. Arbitrary point calibration

Await several seconds, the indicator displays "Ad LD" and displays "0'00000" (the decimal point place have automatically inputted according to the range) after 2 seconds. At this time, load the weights (the weights: $5\%W_{max} < W_{add} < W_{max}$) on the scale platform and input the weights value for the indicator. Await 10 seconds (make sure that the indicator is fully stable), then press [ENTER] to confirm, at this time the indicator displays "PASS" (the indicator is reading the range datum of the scale). After several seconds, the indicator automatically turns to the ambient data group, thus the range calibrating is finished.

Step 4: ambient data group

[F1 X] refers to power-on auto-zero range.

"X=0" refers to no auto-zero.

"X=10" allow to auto-zero, and the zero range is $\pm 10\%$ Max. weighing.

"X=20" allow to auto-zero, and the zero range is $\pm 20\%$ Max. weighing.

If you need to change the above data, press [→] to select and then press [ENTER] to confirm. If don't, directly press [ENTER], at this time the indicator enters F2 setup.

[F2 X] refers to auto zero-tracking range

X=0.5 / 1.0 / 2.0/3.0 (d). The auto zero-tracking function can auto compensate the zero-point change caused by the factor that a little material to be weighed drop down the platform when weighing or due to the temperature change.

If you need to change the above data, press [→] to select and then press [ENTER] to confirm. If don't, directly press [ENTER], at this time the indicator enters F3 setup.

[F3 X] refers to dynamic testing-range.

X=0.5 / 1.0 / 2.0 / 3.0 (d). The non-dynamic condition when to be up for the scale depends on the dynamic testing-range. Never process the zeroing or deducting-tare operation while the scale is under dynamic.

If you need to change the above data, press [→] to select and then press [ENTER] to confirm. If don't, directly press [ENTER], at this time the indicator enters F4 setup.

[F4 X] refers to dynamic testing-time.

X=0.5 / 1.0 / 2.0 / 3.0 (s). The time for scale from dynamic to stabilization depends on the dynamic testing-time.

If you need to change the above data, press [→] to select and then press [ENTER] to confirm. If don't, directly press [ENTER], at this time the indicator enters F5 setup.

[F5 X] refers to digital wave-filtering strength.

X=0 / 1 / 2 / 3. The digital wave-filtering is used for eliminating the weighing change caused by

environment like quake or noise. The lower the wave-filtering strength, the quicker the indicator response-speed, and the less stably the indicator works. On the other hand, the higher the wave-filtering strength, the slower the indicator response-speed, and the more stably the indicator works. The data to be selected are as follows:

- 0—no wave-filtering
- 1—low wave-filtering
- 2—medium wave-filtering
- 3—high wave-filtering

If you need to change the above data, press [→] to select and then press [ENTER] to confirm. If don't, directly press [ENTER], at this time the indicator enters F6 setup.

[F6 X] refers to serial output mode, there are 2 mode to be selected.

X=0 / 1.

X=0 refers to printing output (printer model: TPμP-16S).

X=1 refers to continuous output.

[F7 X] refers to the Baud rate to be selected, with 5 options.

X=1 relevantly 600.

X=2 relevantly 1200.

X=3 relevantly 2400.

X=4 relevantly 4800.

X=1 relevantly 9600.

[F8 X] refers to extension display mode.

X=0 / 1.

X=0 refers to no extension display.

X=1 allow to extension display.

If you need to change the above data, press [→] to select and then press [ENTER] to confirm.

If don't, directly press [ENTER], at this time the indicator enters F9 setup.

[F9 X] refers to user's setup confirming or return to factory setup data.

X=0 confirm the user's setup data.

X =1 return to the factory setup data.

See the following table for the factory setup data:

F1	F2	F3	F4	F5	F6	F7	F8
20	2	0.5	1.0	2.0	1	2	0

If you need to change the data, press [→] to select and then press [ENTER] to confirm. If don't, directly press [ENTER], at this time the indicator displays J1 on (method 2). Pull out the short circuiter W1 and join 1 and 2 pin short, at this time the indicator start to self-check and then enters normal weighing state after finishing the process.

9. Simple Rectifying

Under normal weighing and zero-load state, keep pressing [MODE] for 3 seconds, the indicator displays "0'00000" (the flashing '0' is the selected digit, if don't need to rectify, press [ENTER] to withdraw). Load the rectification weights on the scale platform and input the weight value for

the indicator. Press [ENTER], the indicator displays “wait” and return to normal weighing state and displays the rectification weight after several seconds, thus the rectification operation is completed.

Note: The simple rectifying must meet the following 2 conditions:

- a. The rectification error should be within $\pm 20\%W_c$.
- b. The rectification weight W_c should comply with $W_{max} 10\% \leq W_c \leq W_{max}$

W_c refers to rectification weight and W_{max} refers to Max. weighing.

For example: Simple rectifying to a 30kg scale (rectification weights is 20kg)

Under zero-load state, keep pressing [MODE] for about 3 seconds, the indicator displays “0’000.00” (the flashing ‘0’ at the first digit on the last left is the selected digit). Load 20kg rectification weights on the scale platform, press [→] twice to select the digit-input place, the indicator displays 00’0’0.00. Press [↑] twice to input 00’2’0.00, and then press [ENTER] to confirm, at this time the indicator displays “wait” and displays 20.00 after several seconds, thus the rectification operation is completed.

10. Information Prompt

- a. OVER, which means the weighing value is over-load or short-load.
- b. E32, which means the loaded weight is too little while processing arbitrary point calibration.
- c. E33, which means the load cell output-signal is too low while calibrating the range.
- d. E34, which means the loaded weight is too large while processing arbitrary point test.
- e. NOZERO, which means the gross weight is not zero while entering simple rectifying.
- f. Undo, which means the pressed keys should be loosed so that the indicator enters setting state.
- g. LO-bAT, which means the power capacity of the built-in battery has fully been consumed, at this time you should charge it at once.